

Solar Charger Controller

Solarmate Design Specification

24/48Vdc 40Amp

Revision History

Date	Rev.	Description	Prepared By	Approved By
2012/10/10	00A	Initial release	Denny	Tom

Contents

1.0 Scope.....5

2.0 General Description5

 2.1 Product description5

 2.2 Features5

3.0 Electrical specification.....6

 3.1 Electrical specifications6

 3.2 Efficiency7

4.0 Features and protection specifications8

 4.1 Maximum Power Point Tracking (MPPT) function.....8

 4.2 Optional charge mode8

 4.2.1 Three charge stage8

 4.2.3 Equalization8

 4.3 Battery type choice can apply different charger method.....9

 4.4 Easily install in parallel connection 11

 4.5 Solarmate connector introduction12

 4.6 Solarmate communication port introduction.....13

 4.6.1 Remote: RJ1113

 4.6.2 BTS: RJ1113

 4.7 Battery temperature sensor13

 4.8 LED battery voltage14

 4.8.1. Charge control indications14

 4.8.2. Error mode indication14

 4.9 DC Load15

5.0 User Interface.....15

 5.1 Optional Interface15

 5.2 LED Status Display15

6.0 Environmental.....16

 6.1 Temperature16

 6.1.1 Operating Temperature16

 6.1.2 Transit Temperature16

 6.1.3 Storage Temperature16

 6.2 Safety16

 6.2.1 American market.....16

 6.2.1.1 UL 174116

 6.2.1.2 FCC Part 15B.....16

 6.2.2 European market16

6.2.2.1 EN 50081-1	16
6.2.2.2 EN 50082-1	16
6.2.2.3 EN 60335-1	16
6.3 Humidity	16
6.3.1 Operating Humidity	16
6.3.2 Non-Operating Humidity	16
7.0 Mechanical features	16
8.0 Solarmate dimension drawing	17

1.0 Scope

This document defines the product specification for photovoltaic charge controller, named Solarmate. All specifications are applicable under all operating conditions unless otherwise stated. No changes or deviations from this document are allowed without writing permission from customer.

2.0 General Description

2.1 Product description

Solarmate a 40 amp 24/48 volt *Maximum Power Point Tracking* (MPPT) photovoltaic (PV) battery charge controller. Through the use of MPPT technology, Solarmate can increase charge current up to 30% or more compared to conventional controllers. Solarmate's sophisticated three stage charge control system can be configured to optimize charge parameters to precise battery requirements. The unit is fully protected against voltage transients, over temperature, over current, reverse battery and reverse PV connections. An automatic current limit feature allows use of the full 40 amp capability without worrying about overload or nuisance fuse blow from excessive current, voltage or amp-hour based load control.

Series pass *Pulse Width Modulation* (PWM) charge voltage control combined with a multistage charge control algorithm leads to superior charging and enhanced battery performance. The filtered PWM power control system uses highly efficient and reliable power MOSFET transistors. The MOSFET's are turned on and off at high frequency to precisely control charge voltage and MPPT.

Fully automatic temperature compensation of charge voltage is available to further improve charge control and battery performance. The optional battery temperature sensor is built for long term reliability. The sensor element is environmentally sealed and encapsulated into a plastic lug which adheres to directly to the battery terminal and by RJ11 port connect with the unit, And the Solarmate also includes an isolated RS232 port for connection to a PC computer for data logging and system monitoring.

The Solarmate can easily install in parallel connection, so it also suitable for large system current application condition.

2.2 Features

- 1) A DC Load
- 2) An optional battery temperature sensor ensures precise battery charging
- 3) LED displays to indicate the status of charge
- 4) Lighting protection
- 5) Reverse current at night
- 6) Three-stage battery charging (bulk, absorption, and float) with optional temperature compensation
- 7) Automatic overload protection in both active and passive modes
- 8) Microprocessor controlled
- 9) Silent, pulse width modulated (PWM), high efficiency operation

3.0 Electrical specification

3.1 Electrical specifications

Table 1 Electrical specifications@25°C

Rated Voltage	24/48VDC	
Rated charge current	40A	
Load current	15A	
Input voltage range	30 -100VDC(30-60Vdc for 24V, 60-100V for 48Vdc)	
Max. PV open circuit array voltage	60Vdc for 24,V 105VDC for 48Vdc	
Typical idle consumption	At idle < 10mA	
Overload protection (DC load)	2.0*Inom>5sec 1.5*Inom >20sec 1.25*Inom temperature controlled	
Bulk charge	29.2V(default)	58.4V(default)
Floating charge	26.8V(default)	53.6V(default)
Equalization charge	28.0V(default)	56.0V(default)
Over charge disconnection	29.6V	59.2V
Over charge recovery	27.2V	54.4V
Over discharge disconnection	21.6V (default)	43.2V(default)
Over discharge reconnection	24.6V	49.2V
Temperature compensation	-26.4mV/°C	-52.8mV/°C
Lead acid battery settings	Adjustable	
NiCad battery settings	Adjustable	
Load control mode	1. Low Voltage Reconnect (LVR): Adjustable 2. Low Voltage Disconnect (LVD): Automatic disconnection 3. Reconnection: Includes warning flash before disconnect and reconnection	
Low voltage reconnect	24.0-28.0 Vdc	48.0-56.0 Vdc
Low voltage disconnect	21.0-25.0 Vdc	42.0-50.0 Vdc
Ambient temperature	0-40°C(full load) 40—60°C(de-rating)	
Altitude	Operating 5000 m, Non-Operating 16000 m	
Protection class	IP21	
Battery temperature sensor	BTS - optional remote battery temperature sensor for increased charging precision	
Terminal size (fine/single wire)	#8 AWG	

NOTE:

① The optional battery temperature sensor automatically adjusts the charging process of the controller according to the type of the battery is selected by user through battery type selector. With the battery temperature sensor installed, the controller will increase or decrease the battery charging voltage depending on the temperature of the battery to optimize the charge to the battery and maintain optional performance of the battery.

3.2 Efficiency

The efficiency of the controller shall be a minimum of 97% @ fully charge current.

4.0 Features and protection specifications

4.1 Maximum Power Point Tracking (MPPT) function

Maximum Power Point Tracking, frequently referred to as MPPT, is an electronic system that operates the Photovoltaic (PV) modules in a manner that allows the modules to produce all the power they are capable of. The Solarmate Charge controller is a microprocessor-based system designed to implement the MPPT. And it can increase charge current up to 30% or more compared to traditional charge controllers. (see figure 1).

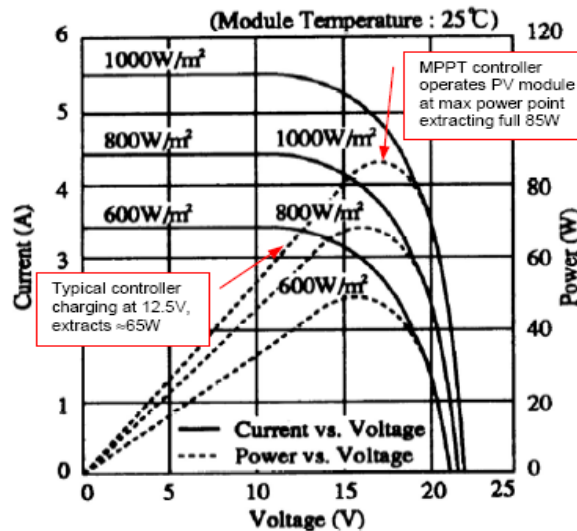

Figure 1 Current, Power vs. Voltage Characteristics

4.2 Optional charge mode

4.2.1 Three charge stage

Solarmate is typically configured for a three stage charging process, Bulk, Absorption and Float.

1) Bulk stage

During this stage, the batteries are charged at the bulk voltage setting. And the unit delivers as much charge current as possible to rapidly recharge the batteries. When the battery voltage reaches the bulk voltage setting, the charge controller activates the next stage (absorption).

2) Absorption stage

During this stage, the unit changes to a constant voltage mode where the absorption voltage is applied to the battery. When charge current decreases to the float transition current setting, the battery is fully charged and the unit switches to the float stage.

3) Float stage

During this stage, the float voltage is applied to the battery to maintain it in a fully charged state.

When battery voltage drops below the float setting for a cumulative period, a new bulk cycle will be triggered.

4.2.3 Equalization

Equalize charging is a special mode of battery charging. During use, the battery's cells can become unequal in the voltage and current they can deliver. This is due to a buildup of sulfate on the plates as well as stratified electrolyte. Sulfate prevents the cells from receiving or delivering full power. If the sulfate is left on the plates,

it will harden, and permanently reduce the battery's capacity. Stratification separates the heavier acid from the water, and the concentrated acid remains at the lower portion of the plates, eventually corroding them. Equalizing the batteries every month or two (depending on usage) prolongs the life of the batteries and provides better battery performance.

To set the Equalize Charge:

- 1) Remove all DC loads connected to the batteries.
- 2) Remove all battery vent caps.
- 3) Check the battery water level, it should be just over the top of the plates (do not over fill). Use only distilled water for filling batteries.
- 4) Set the BATTERY TYPE SELECTOR switch to position "0" or "1".
- 5) Reset the BATTERY TYPE SELECTOR potentiometer to the appropriate setting for the system batteries when the Equalize charge has completed.

4.3 Battery type choice can apply different charger method

The battery type selector (see figure 2) is a 10 position rotary switch used to set the Solarmate for the proper float and bulk voltage levels. These levels are selected depending on the type of batteries used. Refer to the table below for the charge voltages in the various switch positions. Consult the battery manufacturer for optimum battery voltage charging settings.

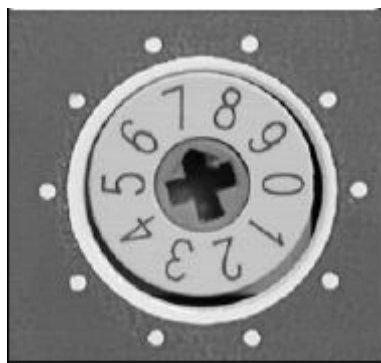

Figure 2 Battery Type Selector

Table 2 Battery Type Selector Switch Settings

Switch Position	Description	24-volt Models		48-volt Models		Charge Function	
		Float voltage (V)	Bulk/ Equalize voltage (V)	Float voltage (V)	Bulk/ Equalize voltage (V)	Equalize charge rate	Equalize time
0	Equalize 1 - equalizes at a rate equal to the battery bank capacity (in amp hours) divided by 40.	26.4	*30	52.8	*60	Battery Capacity Setting	6 hrs. minimum 12 hrs. maximum
1	Equalize 2 -charges at a rate set by the BATTERY CHARGER RATE control.	26.4	*31	52.8	*62	Battery Charger Rate Setting (manual)	6 hrs. minimum 12 hrs. maximum
2	Deep Cell Lead Acid 2	26.6	30	53.2	60	Provides an additional Float and Bulk settings for deep cycle, lead acid batteries. Refer to the battery manufacturer recommendation for Float and Bulk settings.	
3	Not Specified	27.2	28.6	54.4	57.2	Provides an additional setting of Bulk and Float voltages.	
4	Gel Cel 2	27.4	28.8	54.8	57.6	Recommended for gel cell batteries that specify high float voltages. Check with the battery manufacturer.	
5	Gel Cell 1	27	28.2	54	56.4	Typical gel cell setting.	

6	PcCa-lead Calcium	26.4	28.6	52.8	57.2	Use this setting for sealed type car batteries.
7	Deep Cycle Lead Acid 1 (Default Setting)	26.8	29.2	53.6	58.4	Factory setting for typical deep cycle lead acid batteries.
8	NiCad 1	28	32	56	64	Use for NiCad battery systems.
9	NiCad 2	29	32	58	64	Recommended for use with nickel iron batteries.

Table 2 Battery Type Selector Switch Settings

Important:

1. Switch positions “0” and “1” are for monthly battery maintenance only. Return the switch to the appropriate position for the system’s batteries when Equalize charging has completed. NEVER EQUALIZE GEL BATTERIES! Use together with BATTERY CHARGER RATE potentiometer (position1) or BATTERY CAPACITY potentiometer (position 0).
2. Equalize voltages are displayed in the table with an asterisk (*) – Switch positions “0” and “1” only.
3. Switch position “7” is the default values as shipped from the factory.
4. Always refer to the battery manufacturer’s specifications for equalization.

4.4 Easily install in parallel connection

In order to get more than 40A charge current, the Solarmate can be connected in parallel.

For example:

connecting 2 Solarmate in parallel can get 80A charger current, and connecting 3 Solarmate in parallel can get 120A charger current.

See figure 3.

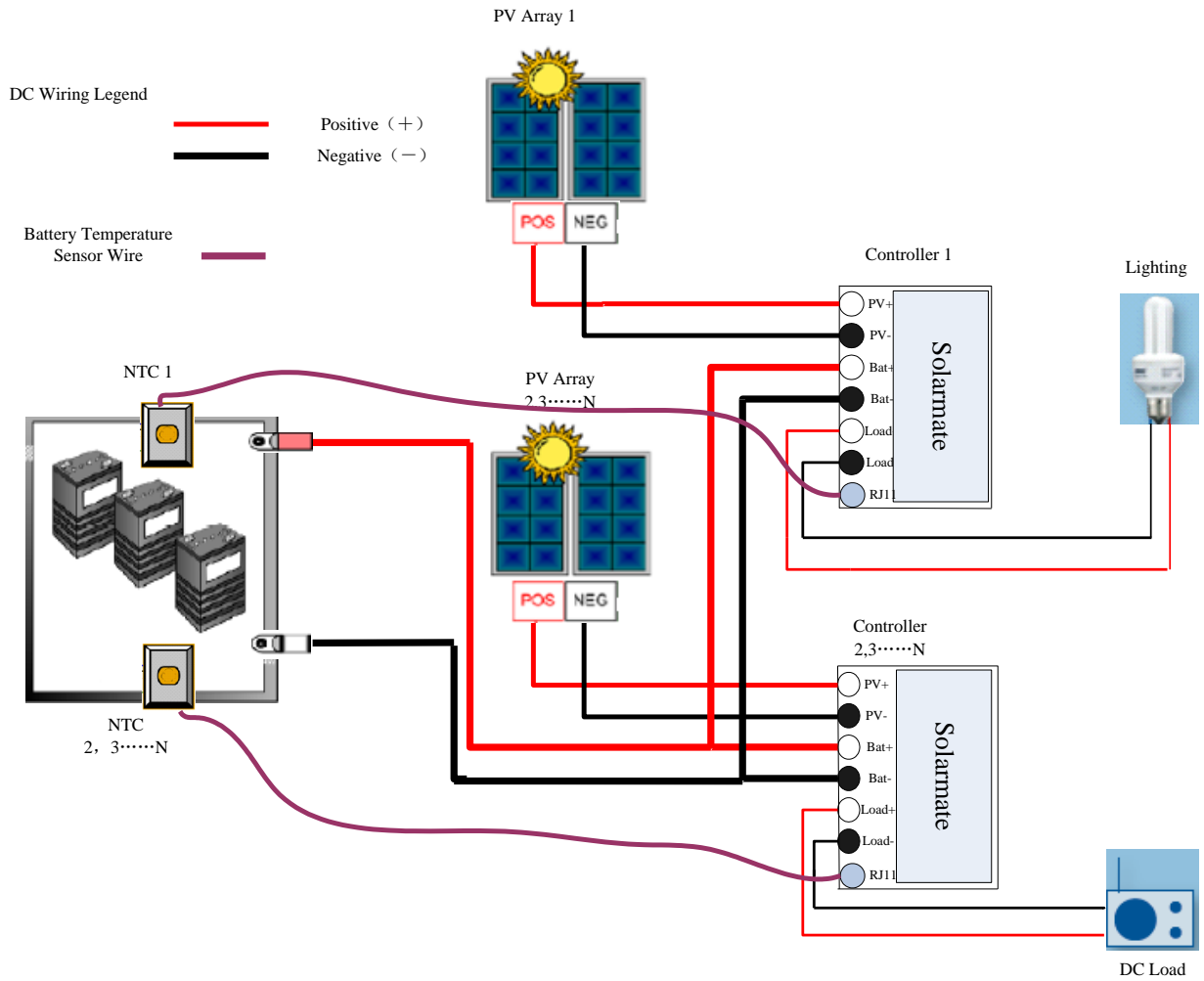
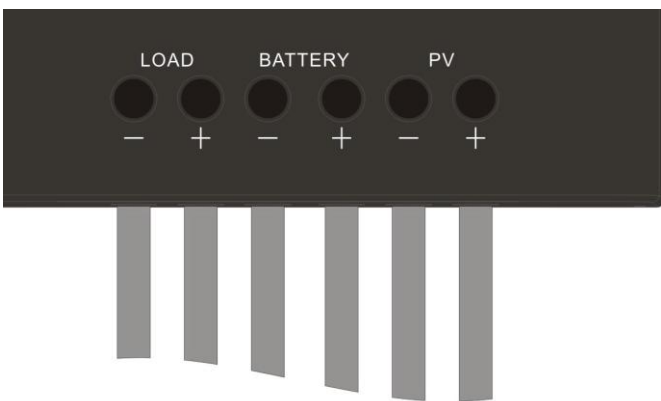

Figure 3 parallel connection

4.5 Solarmate connector introduction



Load: 15A DC load

Battery: 40A rated charge current

PV: photovoltaic system

4.6 Solarmate communication port introduction

4.6.1 Remote: RJ11

4.6.2 BTS: RJ11

4.7 Battery temperature sensor

The charge voltage required by batteries changes with battery temperature. Temperature compensation of charge voltage enhances battery performance and life, and decreases battery maintenance. Automatic temperature compensation can be provided through use of the optional battery temperature sensor. The following table describes approximately how much the voltage may vary depending on the temperature of the batteries.

Table 3 Variances in charging voltage based on battery temperature

Temperature (around the BTS)		24-volt units		48-volt units	
Celsius	Fahrenheit	Lead Acid (12 cells)	NiCad (20 cells)	Lead Acid (24 cells)	NiCad (40 cells)
60	140	-2.1	-1.4	-4.2	-2.8
55	131	-1.8	-1.2	-3.6	-2.4
50	122	-1.5	-1	-3.0	-2
45	113	-1.2	-0.8	-2.4	-1.6
40	104	-0.9	-0.6	-1.8	-1.2
35	95	-0.6	-0.4	-1.2	-0.8
30	86	-0.3	-0.2	-0.6	-0.4
25	77	0	0	0	0
20	68	0.3	0.2	0.6	0.4
15	59	0.6	0.4	1.2	0.8
10	50	0.9	0.6	1.8	1.2
5	41	1.2	0.8	2.4	1.6
0	32	1.5	1	3.0	2
-5	23	1.8	1.2	3.6	2.4
-10	14	2.1	1.4	4.2	2.8
-15	5	2.4	1.6	4.8	3.2
-20	-4	2.7	1.8	5.4	3.6
-25	-13	3	2	6	4
-30	-22	3.3	2.2	6.6	4.4
-35	-31	3.6	2.4	7.2	4.8
-40	-40	3.9	2.6	7.8	5.2

Temperature compensation is based on battery type-5mv /cell for lead acid type batteries and 2mv/cell for alkaline type batteries (NiCad or NiFe). The temperature compensation calculations are derived from the following table

The table Temperature Compensation Calculation

Battery Type	24 -volt unit	48-volt unit
Lead Acid	0.06 volts (30mv) per degree Celsius	0.12 volts (60mv) per degree Celsius
NiCad	0.04 volts (20mv) per degree Celsius	0.08 volts (40mv) per degree Celsius

4.8 LED battery voltage

The Solarmate has one multicolor LED and one green LED to indicate the operating status of the controller. The green LED indicates whether the charging source is functioning properly when it display solid green or the type of the fault when it flash. And the multi color LED indicates the particular operating mode and the batteries capacity level.

4.8.1. Charge control indications

Single Color LED Indication	PV>BV	PV<BV
	Charge On	Charge Off
	Light On	Turn Off

Figure 5 Single color of the LED indicators

Battery. Cap.	<LVD	<LVR, >LVD,	>LVR
LED Indication	Red	Orange	Green

Figure 6 Battery Cap. LED indicators

4.8.2. Error mode indication

If the single color LED or multi color LED flashes, it indicates over temperature condition, over current condition, low voltages disconnect condition, reverse connection for solar module condition and over voltage of load condition. The green LED’s flash time depends on the condition or function they are display. See table 4.

Table 4 Error Mode Indications

Error Mode	Single Color LED	Multi Color LED
Low Voltage Disconnect	Turn off	Blink 1, off 6s (orange)
Over Voltage of Load	Blink 1, off 6s	Turn off
Over temperature	Blink 2, off 6s	Turn off
Over current	Blink 3, off 6s	Turn off

NOTE:

When the controller is charging, the green LED will be solid green.

- 1) Low Voltage Disconnect

When connected with DC load, if voltage remains below the Low Voltage Disconnect setting, the controller will disconnect after a 6-minute delay period. And the controller waits until the voltage rises above the Low Voltage Recovery setting.

- 2) Over Voltage of Load

If the controller detects an over voltage of load, it will disconnect the load.

3) Over Temperature

The temperature of the controller's transistors is continuously monitored. This protects the charge controller from damage in high temperature environments. If excessive temperatures are detected while operating in charge mode, the controller will decrease the charge current to reduce the transistor temperature and the green led will be solid green. If the Solarmate connected with DC load, the load is disconnected before the transistors reach an excessive temperature and the green LED flashes. Once the temperature has dropped, the loads are reconnected.

4) Over Current of the Load

If the controller detects an overload or short circuit of the load, it will automatically resets the over current protection system every 6 minutes. If the default is still present, the controller will shut off and wait another 6 minutes. This will occur continuously until the problem is corrected.

4.9 DC Load

The Solarmate can control DC load

- 1) Automatic low voltage disconnect with adjustable set point.
- 2) Automatic low voltage recovery with adjustable set point.
- 3) Automatic reconnection of loads after low voltage disconnect occurs.
- 4) Electronic short-circuit overload, over temperature and over voltage of load improves reliability.

5.0 User interface

5.1 Optional interface

The battery type selector

5.2 LED status display

A multi color LED and a single color LED indicate the operating/battery voltage status.

6.0 Environmental

6.1 Temperature

6.1.1 Operating Temperature

0°C to 40°C (40°C to 60°C (de-rating))

6.1.2 Transit Temperature

25 °C to +70 °C

6.1.3 Storage Temperature

-25 °C to +70 °C

6.2 Safety

6.2.1 American market

6.2.1.1 UL 1741

6.2.1.2 FCC Part 15B

6.2.2 European market

6.2.2.1 EN61000-6-3:2001

6.2.2.2 EN61000-6-1:2001

6.2.2.3 EN 60335-1

6.3 Humidity

6.3.1 Operating Humidity

20 to 80% relative humidity (non-condensing)

6.3.2 Non-Operating Humidity

5 to 95% relative humidity, 38.7°C maximum wet bulb temperature with no cosmetic damage.

7.0 Mechanical features

Items	Specification	Remark
Dimension (H x W x D)	Depth: ≤ 192 mm Height: ≤ 66 mm Width: ≤ 140 mm	
Unit Weight	1.4Kg	
Warranty	2 years	
Mounting	Vertical wall mount - indoor only	
Cooling	Natural cooling	

8.0 Solarmate dimension drawing

